

Schunk Brush Holders



Types and Variations



Types and Variations

Single Brush Holders



Applicable in commutator machines, large variety of types, different pressure systems, sheet metal and cast designs

Plug-in Brush Holders and Elements



Special brush holders for turbo generators, safe brush change during running machines, simple brush wear control, plug-in elements for pilot exciters, simple and multiple types

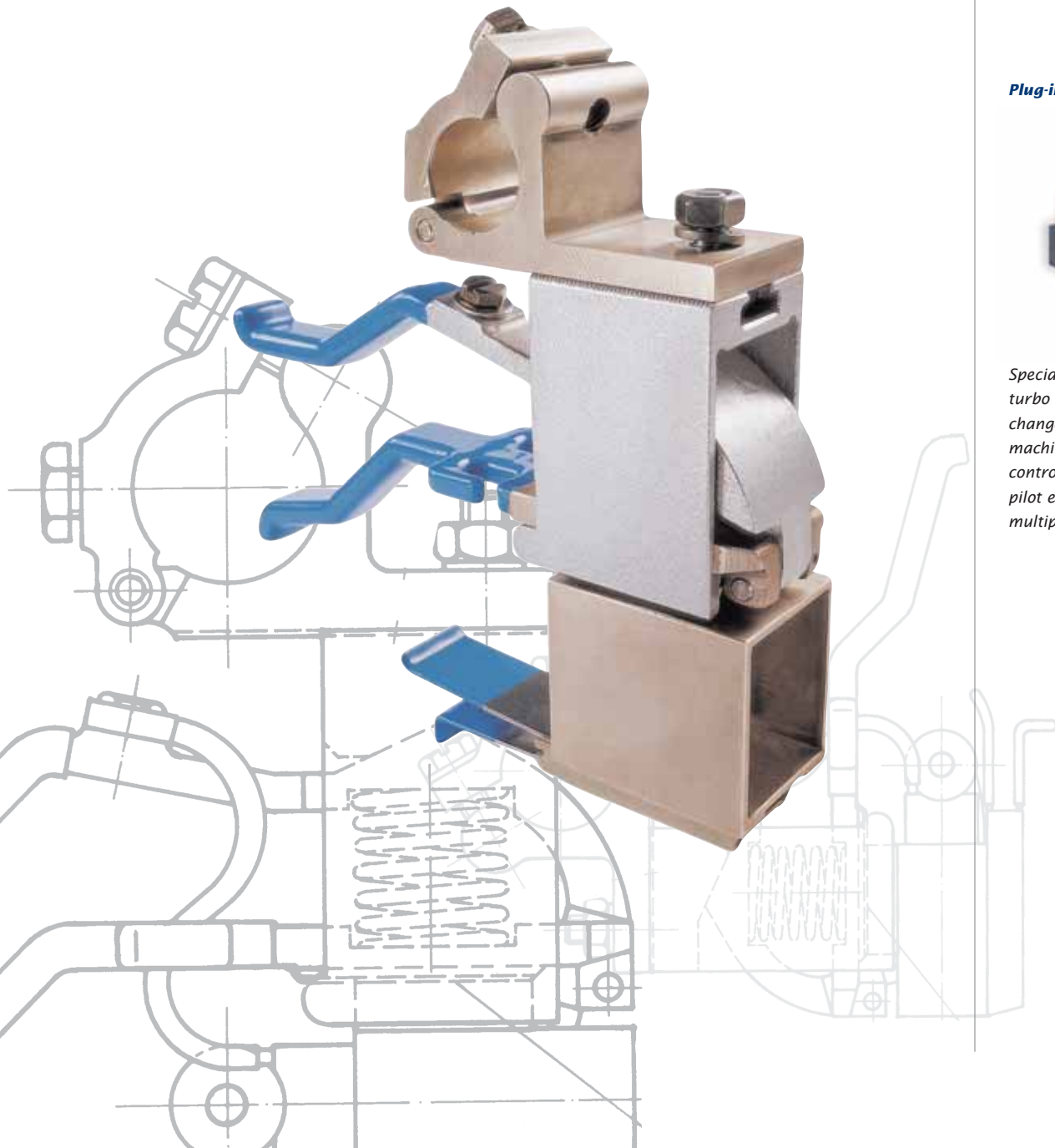

Tandem Brush Holders



Preferably for large machines, for heavy operating conditions, for tangentially broad carbon brushes, independently working pressure devices for both brushes

Double Clamp Brush Holders



For slipring machines, sheet metal and cast designs, adjustable for different slipring diameters, with and without pressure adjustment, with and without phase connections

Leg Brush Holder



For slip-ring rotor machines, simple and double leg design, with one or two-piece brass shim, legs out of brass plate

Flange Brush Holders



Simple and multiple types of flange brush holders out of brass plate or gravity die casting, different pressure elements

Multiple Brush Holders



More compactly designed as single holders, shorter commutator possible, attachment slot before the brush boxes

Row Holders with Wear Leveling



Application preferably for row holders, pressure balance at a row holder by means of a directed counter acting force by a spring forced frame, extension of the brush service life

Current Leads



Application for adjustable clutches, bronze brushes for unlubricated operation, textural brushes for wet run, oil-tight installation

Tubular Brush Holders



Use in small motors, simple brush change, brush box out of brass profile or sheet metal, insulated with laminated paper or plastic-repressed, plug-in connection, soldering groove or screw connection

Accessories



Clamps of all kinds for holder attachment



Insulated attaching studs with laminated paper and plastic-repressed



Rocker ring

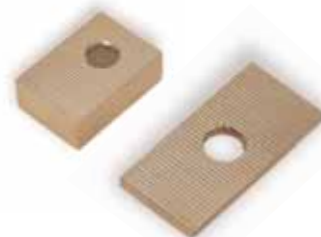

Clearance pieces and shims

Information Hotline

Please do not hesitate to contact us if you have any questions about Schunk Brush Holders as well as

- Application Technology
- Prototyping
- Test and Laboratory Equipment
- Test Stands
- CAD/CAM Design/Development
- Materials

Other Products and Services

- Contacts and Connections
- Systems for Power Transmission
- System Assemblies
- On-site Service
- Oscillation Examinations
- 3D Measurements

Contact

Telephone: +49 (6 41) 803-0
Telefax: +49 (6 41) 803-139

E-Mail:
sales.sbi@schunk-group.com

Schunk Bahn- und Industrietechnik GmbH

Hauptstrasse 97
35435 Wettenberg
Germany

Telephone: +49 (6 41) 803-0
Telefax: +49 (6 41) 803-139

www.schunk-sbiw.com